

Swing Gates



Blitz

230 V, 120V and 24 V irreversible electromechanical pivoting arm actuator for swing gates with leaves up to 3 m in length and weighing 800 kg

The irreversible nature of the motor guarantees the effective locking of the leaves. However, in the absence of power, the gate can be operated manually by simply rotating the internal release lever. Access to the internal release lever is protected by a hatch with a personalised key

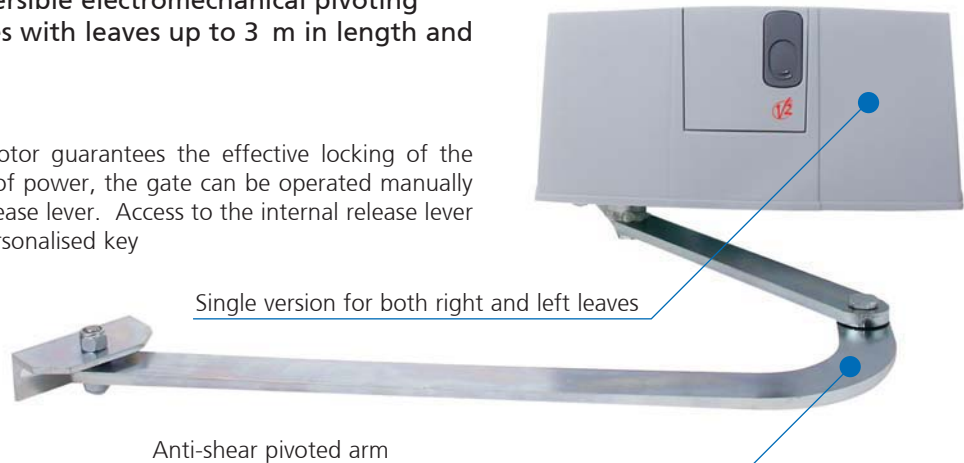

Single version for both right and left leaves

Anti-shear pivoted arm

Protective hatch with customized key



Internal release lever



Built-in cabled limit switches: for fewer connections and speed of installation



BLITZ 24V:

24 VDC version for swing gates with leaves weighing up to 800 kg. Ideal for intensive use

Technical features

Blitz models	Blitz 24V (22E002)	Blitz 120V (22E003)	Blitz 230V (22E001)
Power supply	24 VDC	120 V - 60 Hz	230 V - 50 Hz
Idling current	1,5 A	3,8 A	1,8 A
Full load current	1,5 A	4,5 A	2,5 A
Max. power	45 W	400 W	400 W
Capacitor	-	30 µF	8 µF
Operating speed	1,2÷1,8 Rpm	1,9 Rpm	1,6 Rpm
Torque	320 Nm	340 Nm	340 Nm
Working temperature	-30 / +60 °C	-30 / +60 °C	-30 / +60 °C
Thermoprotection	-	140 °C	140 °C
Protection	IP 34	IP 34	IP 34
Working cycle	80 %	20 %	20 %
Motor weight	14,6 Kg	14,6 Kg	14,6 Kg

Operating limits	
Leaf length (m)	Weight (Kg)
3	500
2,5	600
2	800

Swing Gates



Dimensions

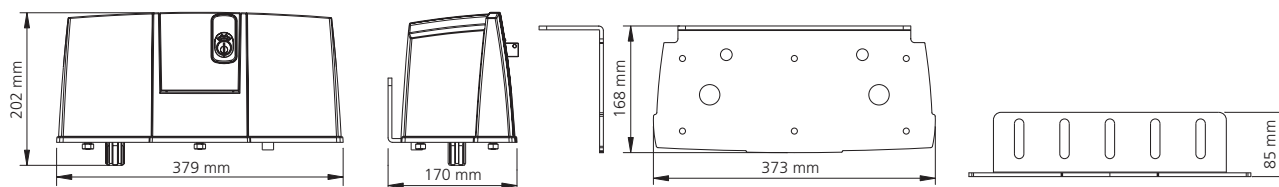

Guide to residential installation

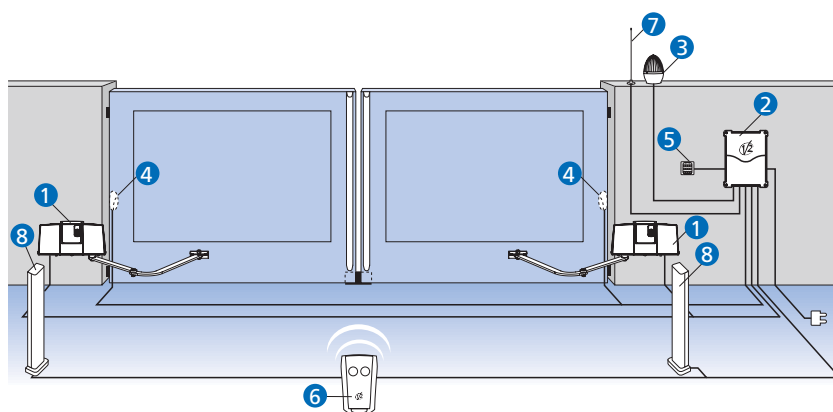

The installation of safety edges on fixed parts or moving leaves is essential in cases where a comprehensive risk analysis of motorised doors requires it

Equipment for standard installation

1	BLITZ 230 V actuator	(cable 4 x 1 mm ²) (Blitz 24V :cable 1,5 x 2 mm ²)
2	CITY 1 advanced control unit	(cable 3 x 1,5 mm ²)
3	Flashing light	(cable 2 x 1,5 mm ²)
8 4	Pair of photocell detectors	(RX : cable 4 x 1 mm ²) (TX : cable 2 x 1 mm ²)
5	External keypad switch (radio) Plug-in radio card	(cable 2 x 1 mm ²)
6	PHOENIX dual channel transmitter	
7	Tuned antenna	(cable RG-58)