

Garage doors



Jet

Irreversible electromechanical actuator for spring-balanced sectional doors up to 2.6 m in height and counterweight-balanced doors up to 2.8 m in height. Maximum force 650 N

External push-button for operating the motor reducer and changing control unit functions without opening the protective casing



Built-in courtesy light



Practical and functional connection diagram printed on the product label: very simple and clear

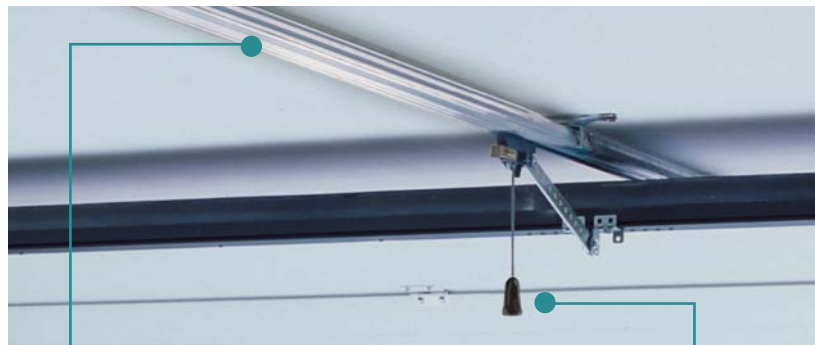

Single length 3 m rails, for maximum ease of assembly

Practical and functional release system

- The special "Push & Pull" chain drive system allows easy and rapid installation
- 230 VAC built-in control unit
- Self-learning programming, memorising the times, braking, and force necessary for both opening and closing
- Built-in 433.92 MHz receiver allowing the use of Phoenix series transmitters
- Magnetic encoder movement control

Dimensions

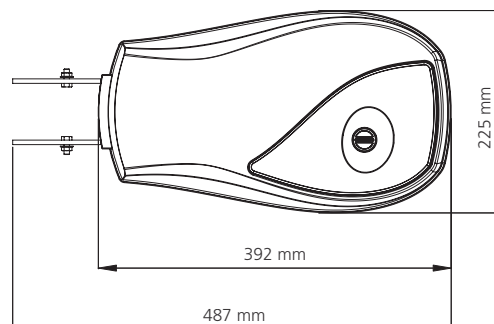
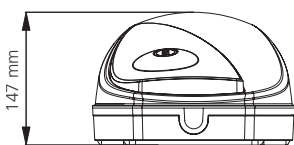

Garage doors



Installation diagrams

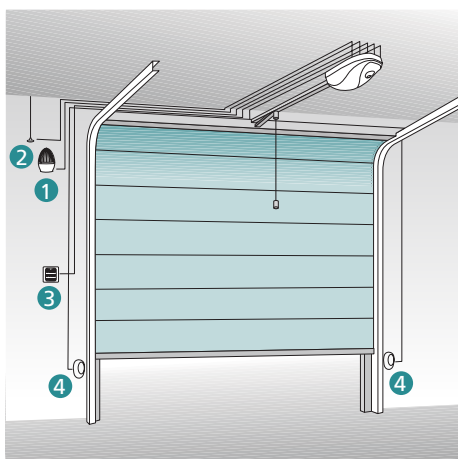

Sectional door

- ① Flashing light (cable 2 x 0,5 mm²)
- ② Tuned antenna (cable RG-58)
- ③ Key switch or digital radio-controlled switch (cable 2 x 1 mm²)
- ④ Pair of photocell detectors (RX : cable 4 x 1 mm²) (TX : cable 2 x 1 mm²)

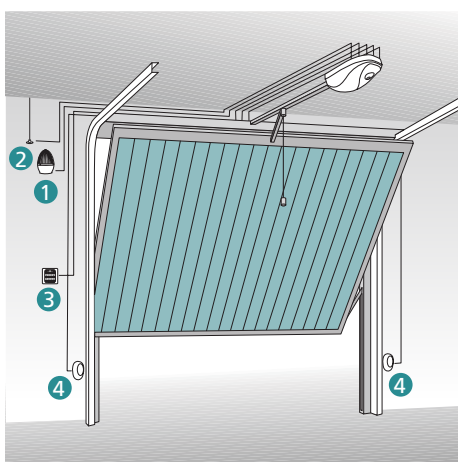

Counterweight-balanced door

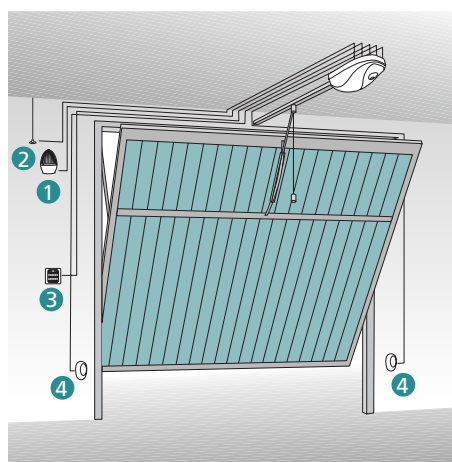

Spring-balanced door

Technical features

Jet models	Jet 650 (25A001)	Jet 650-120V (25A003)
Power supply	230 V - 50 Hz	120 V - 60 Hz
Average speed	12 cm/s	12 cm/s
Line absorption	1 A	2 A
Absorbed power	230 W	240 W
Full load current	8 A	8 A
Max. load of accessories 24V	10 W	10 W
Working temperature	-20 / +50 °C	-20 / +50 °C
Protection	IP 20	IP 20
Working cycle	30 %	30 %
Motor weight	10 Kg	10 Kg
Nominal force	650 N	650 N