

Sectional overhead door Prisma 45^{Stucco}

exterior industrial door with fully glazed sections for high natural light ingress, stucco-embossed bottom panel

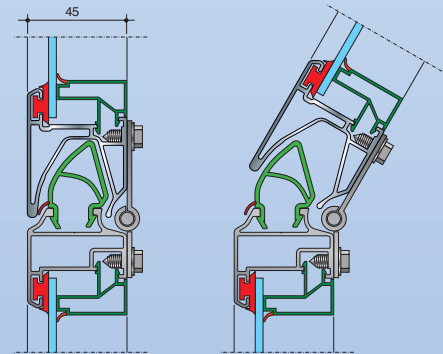
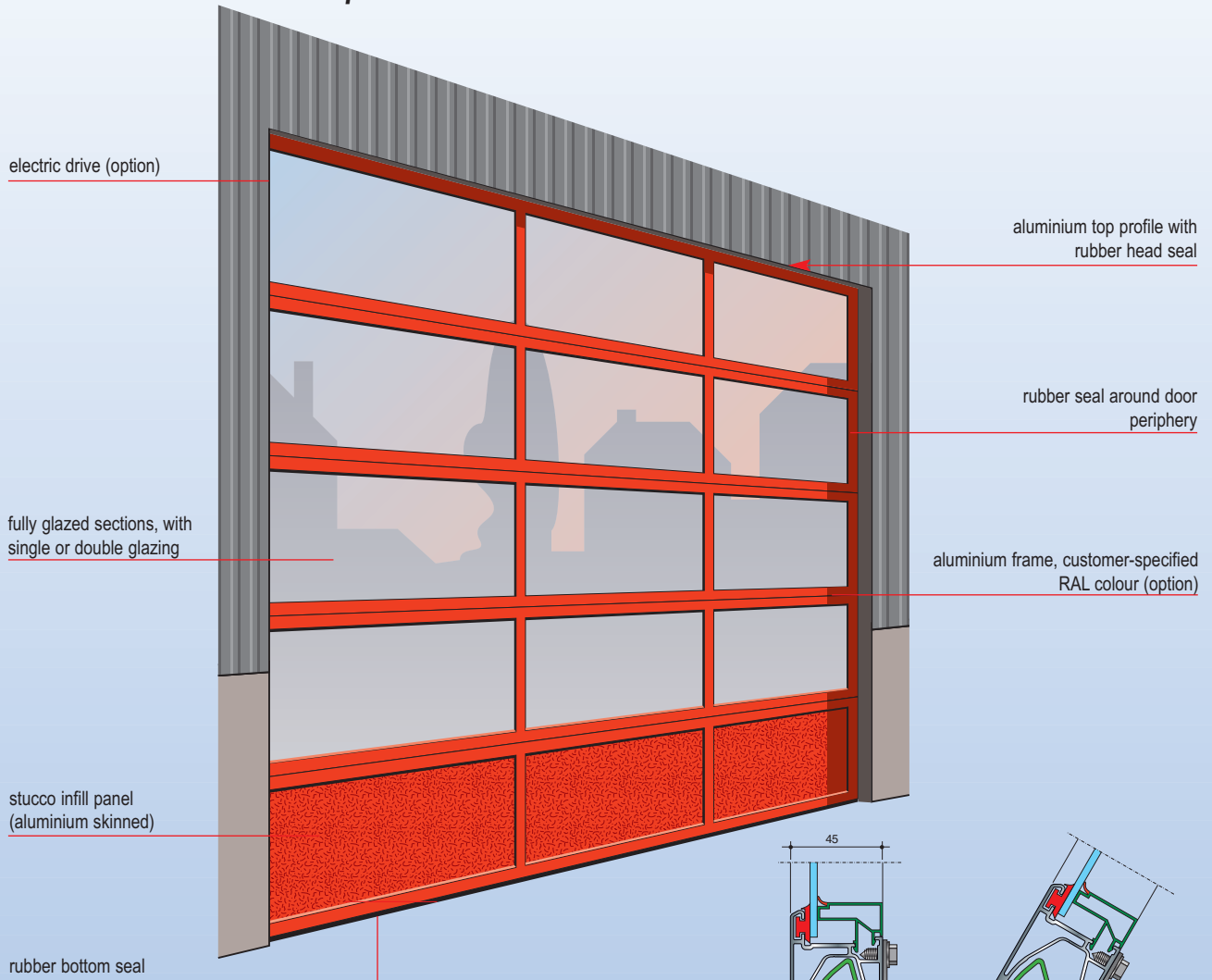

Finger pinch protection detail

Features

- robust and stable panel design
- finger pinch protection
- available in a wide choice of (RAL) colours
- also available with a wicket door
- superior quality door hardware
- manual or electric operation
- optimum safety
- draught-proof seals around the door periphery
- satisfies Norm EN12604.

Novoferm's insulated sectional overhead door, type PRISMA 45 STUCCO, fully glazed for maximum natural light ingress, available with either manual or electric operation. These doors are used in industrial buildings, public utilities and garages. There is a choice of specifications, finishes, operators and installation arrangements (track systems).

Components and construction

Novoferm's sectional overhead door, type PRISMA 45 STUCCO, is made of fully glazed sections. The bottom section is not transparent. As the door opens, the sections slide back under the ceiling. Torsion springs balance the door's weight, making manual operation possible. In addition to the standard lift track system, high lift, vertical lift, roof angle and low headroom track systems are also available.

Materials

- anodised aluminium frame sections, fitted with acrylic (single or double) glazing; other types of infill materials are also available
- the bottom section also consists of an aluminium frame, however non-anodised aluminium stucco panels are used as the infill material
- panel height 625 and 500 mm, or to customer specification (option)
- 2 mm thick steel tracks, sendzimir-galvanised
- galvanised steel door hardware
- door hardware mounted using electrolytically galvanised, self-tapping screws with integral, knurled lock-washers
- rollers with nylon wheels and chromate-dipped, 11 mm steel shaft.
- steel cables with a safety factor of 6 protected by a safety frame
- EPDM top, side and floor seals
- EPDM seals between the panels

Dimensions

- maximum door width7000 mm
- maximum door height8000 mm
- maximum door surface area46 m²
- minimum door width1000 mm.

Drive

Electric operation is offered in addition to manual operation by pullcord or hand chain drive. The control pcb is integral to the drive unit.

Operators

- manual operation: pullcord or hand chain drive
- electric operation:
 - push-buttons (open-stop-close) in 'deadman configuration' without a bottom safety edge
 - push-buttons (open-stop-close), including a self-testing bottom safety edge.

Safety features

Safety features as required by EN 12604.

Structural requirements and connection

- separate technical data sheets are available for all designs and track systems, which detail dimensional and structural requirements
- if an electric drive is specified, a female CEE plug (16A 3 phase + 0 + earth) must be installed within 1 m of where the drive and/or control unit will be positioned (third party supply).

Technical details (if an electric drive is fitted)

electrical supply230V / 3N~400V/50Hz/16A
 IP ratingIP54
 power requirement:
 (design with spring package)max. 450 Watt
 (springless design)max. 2,5 kW.

Auxiliary components/ options/ accessories

Door panel profiles,

- door-frame (interior and/or exterior face) in a colour of the customer's choice(to RAL specifications)
- heavy-duty shoot bolt with return spring
- integral wicket door, outward opening, with door closer and profile cylinder lock (max. sectional door width 6000 mm).

For electrically operated doors

- other operation configurations are possible
- IP65 rating.
- springless design (standard for doors > 700 kg door panel weight). This is a special design without torsion springs. The shaft is directly driven by a heavy-duty electric drive, without the aid of balance springs.

Sectional overhead door Prisma 45^{ISO}

exterior industrial door with glazed sections for high natural light ingress,
Thermo bottom panel

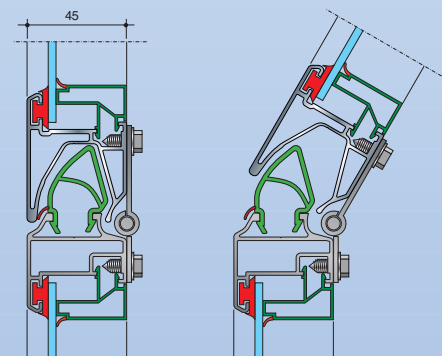
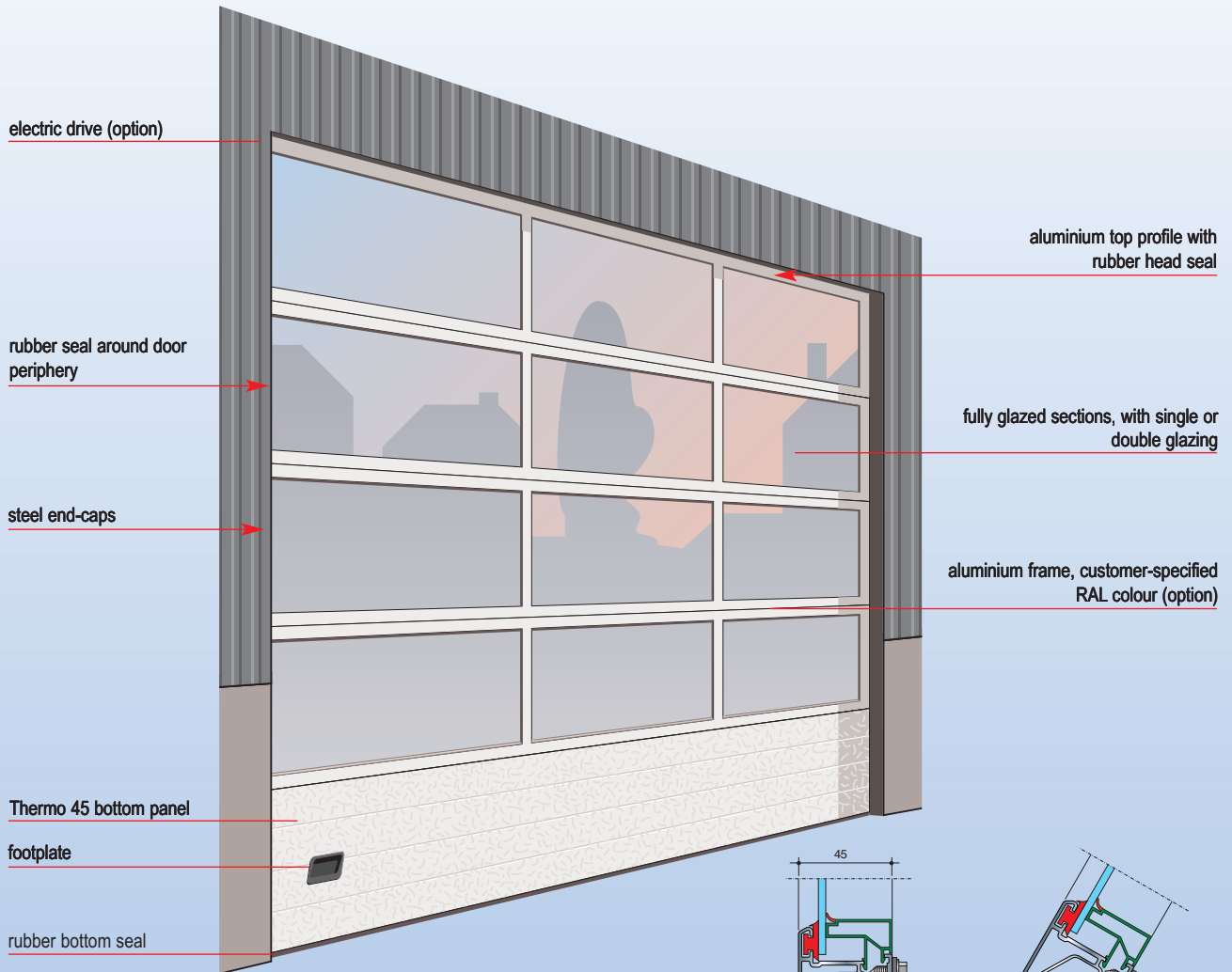

Finger pinch protection detail

Features

- robust and stable panel design
- finger pinch protection
- available in a wide choice of (RAL) colours
- also available with a wicket door
- superior quality door hardware
- manual or electric operation
- optimum safety
- draught-proof seals around the door periphery
- satisfies Norm EN12604.

Novoferm's insulated sectional overhead door, type PRISMA 45 ISO, fully glazed for maximum natural light ingress, available with either manual or electric operation. These doors are used in industrial buildings, public utilities and garages. There is a choice of specifications, finishes, operators and installation arrangements (track systems).

Components and construction

Novoferm's sectional overhead door PRISMA 45 ISO is made of fully glazed sections. The bottom section is not transparent. As the door opens, the sections slide back under the ceiling. Torsion springs balance the door's weight, making manual operation possible. In addition to the standard lift track system, high lift, vertical lift, roof angle and low head-room track systems are also available.

Materials

- anodised aluminium frame sections, fitted with acrylic (single or double) glazing; other types of infill materials are also available
- the bottom section consists of an insulated steel sandwich panel with a PUR foam core
- panel height 625 and 500 mm, or to customer specification (option)
- 2 mm thick steel tracks, sendzimir-galvanised
- galvanised steel door hardware
- door hardware mounted using electrolytically galvanised, self-tapping screws with integral, knurled lock-washers
- rollers with nylon wheels and chromate-dipped, 11 mm steel shaft.
- steel cables with a safety factor of 6
- EPDM top, side and floor seals
- EPDM seals between the panels

Dimensions

- maximum door width.....7500 mm
- maximum door height8000 mm
- maximum door surface area.....46 m²
- minimum door width.....1000 mm.

Drive

Electric operation is offered in addition to manual operation by pullcord or hand chain drive. The control pcb is integral to the drive unit.

Operators

- manual operation: pullcord or hand chain drive
- electric operation:
 - push-buttons (open-stop-close) in 'deadman configuration' without a bottom safety edge
 - push-buttons (open-stop-close), including a self-testing bottom safety edge.

Safety features

Safety features as required by EN 12604.

Structural requirements and connection

- separate technical data sheets detailing dimensional and structural requirements are available for all designs and track systems
- if an electric drive is specified, an isolator switch must be installed within 1 m of where the drive and/or control unit will be positioned (third party supply).

Technical details (if an electric drive is fitted)

electrical supply230V / 3N~400V/50Hz/16A
 IP ratingIP54
 power requirement:
 (design with spring package)max. 450 Watt
 (springless design)max. 2,5 kW.

Auxiliary components/ options/ accessories

- door-frame (interior and/or exterior) in a colour of the customer's choice (to RAL specifications)
- heavy-duty shoot bolt with return spring
- integral wicket door, outward opening, with door closer and profile cylinder lock (max. sectional door width 6000 mm).

For electrically operated doors

- other operation configurations are possible
- IP65 rating.
- springless design (standard for doors > 700 kg door panel weight). This is a special design without torsion springs. The shaft is directly driven by a heavy-duty electric drive, without the aid of balance springs.